

ICS Compensating Stacker for inline applications

The stacker interlocks products crosswise to produce a solid bundle for optimal palletizing.

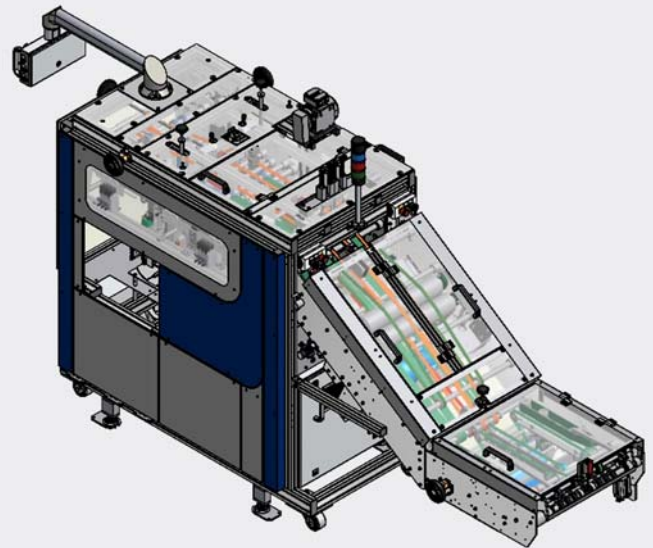

Technical Specifications

Measurements

Total height	approx. 2228 mm
Total width	approx. 1377 mm (without outlet belt)
Total length	approx. 3492 mm (depending on inlet height)
Input height	600 - 900 mm
Output height	860 - 890 mm
Height partial batch	max. 160 mm
Height complete bundle	max. 300 mm
Product format	min. 100 - 140 mm (optional with servo adjuster) max. 315 - 480 mm
Product diagonal	max. 580 mm (Attention please)

Pneumatic system

Air pressure	min. 6 bar
Air consumption	max. 1,0 Nm ³ /min., unoled, dry air

Electrical supply data

Voltage	400 V, 3 phase, N, PE, 50 Hz
Power input	1,5 kW
Fuse	20 A slow-blow fuse
Cycle	≥ 1.2 sec. (depending on the product)

Example production speed at DIN A4 (48 pages) without inserts

Shingle stream magazine infeed

Maximum performance: 100.000 c/h at 35 copies per batch

Data refers to DIN A4 products without insert

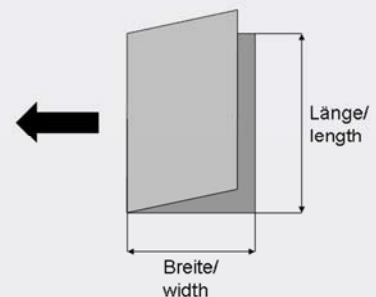

*) pre-positioning turning basket see page 2

SEGBERT

PALLETIZING & AUTOMATION

Gutenbergstraße 16
D-48683 Ahaus

Telefon +49 (0) 25 61 / 95 04-0
Telefax +49 (0) 25 61 / 95 04-20
Mail segbert@segbert.com

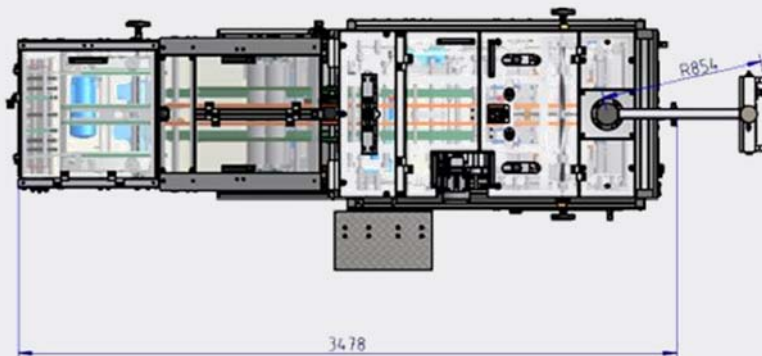
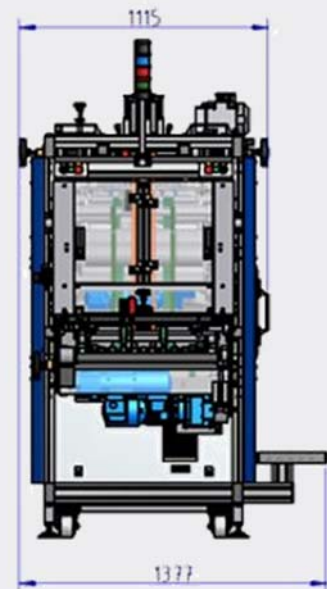
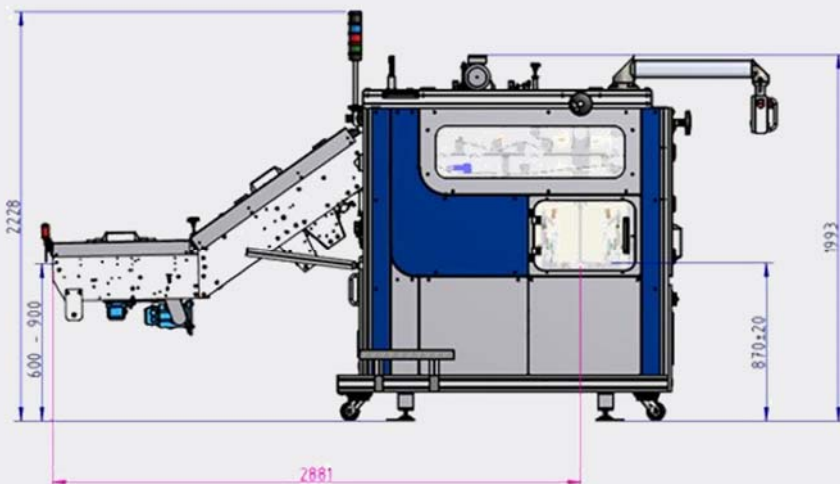
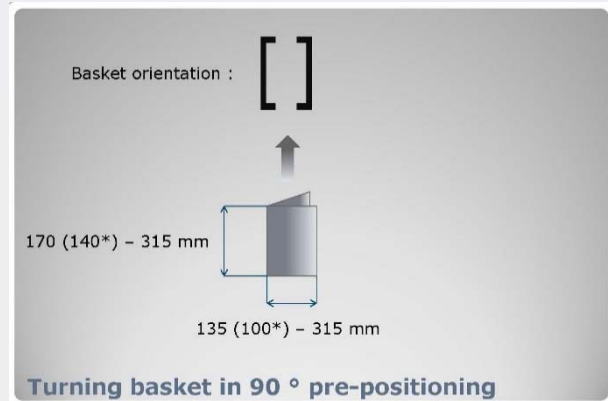
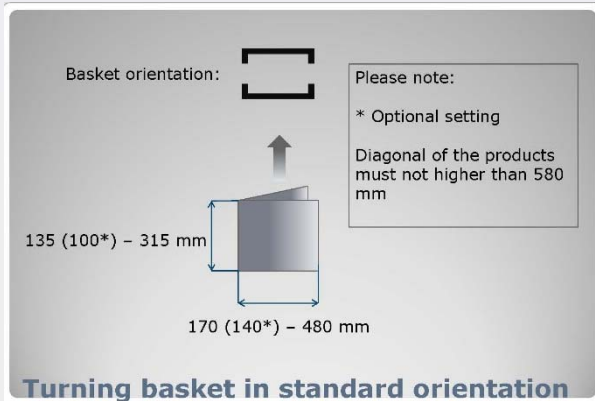

Volksbank Gronau Ahaus eG IBAN: DE33 4016 4024 0602 0192 00 BIC: GENODEM1GRN

Sitz der Gesellschaft: Ahaus Registergericht: Coesfeld, HRA 2848 UStID.: DE123788344 Steuernummer: 301/5750/0035
Komplementär: Segbert Verwaltungsgesellschaft mbH Sitz: Ahaus Registergericht: Coesfeld, HRB 4251
Geschäftsführer: Klaus Segbert